

Operator's Manual

LSM75BVG, LSM55H, LSM80H

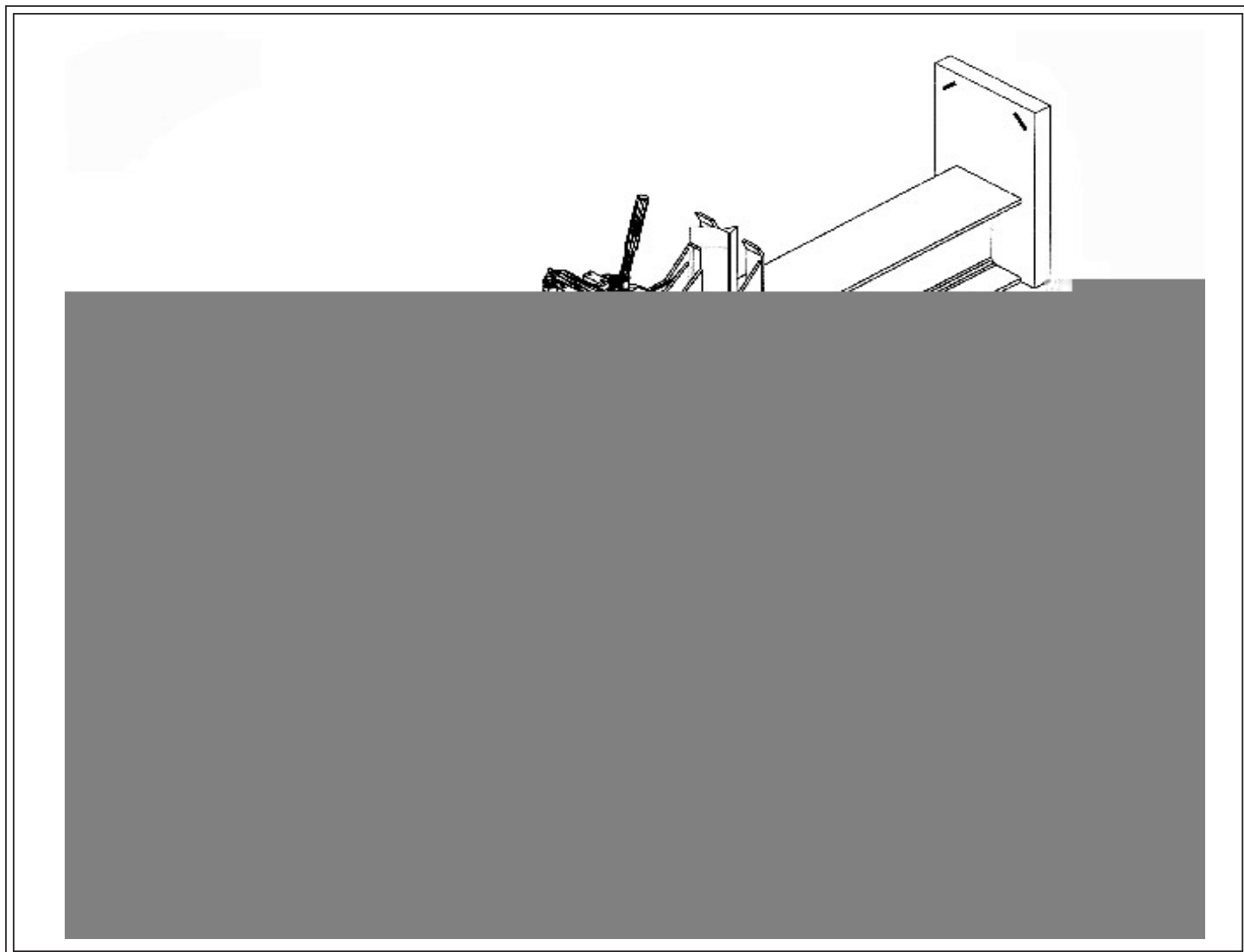

⚠ WARNING: READ ENTIRE MANUAL BEFORE ATTEMPTING TO OPERATE MACHINE!

If incorrectly used this machine can cause severe injury. Those who use and maintain this machine should be trained in its proper use, warned of its dangers, and should read the entire manual before attempting to set up, operate, adjust, or service this machine.



The Engine Exhaust from this product contains chemicals known to the State of California to cause cancer, birth defects or other reproductive harm.

IMPORTANT: THIS UNIT IS EQUIPPED WITH AN INTERNAL COMBUSTION ENGINE AND SHOULD NOT BE USED ON OR NEAR ANY UNIMPROVED FOREST-COVERED, BRUSH-COVERED, OR GRASS-COVERED LAND UNLESS THE ENGINE'S EXHAUST SYSTEM IS EQUIPPED WITH A SPARK ARRESTER MEETING APPLICABLE LOCAL LAWS (IF ANY). IF A SPARK ARRESTER IS USED, IT SHOULD BE MAINTAINED IN EFFECTIVE WORKING ORDER BY THE OPERATOR. IN THE STATE OF CALIFORNIA, A SPARK ARRESTER IS REQUIRED BY LAW (SECTION 4442 OF THE CALIFORNIA PUBLIC RESOURCES CODE). OTHER STATES MAY HAVE SIMILAR LAWS. FEDERAL LAWS APPLY ON FEDERAL LANDS. SEE YOUR AUTHORIZED SERVICE CENTER FOR A SPARK ARRESTER.

Important Rules for Your Safety



Before operating this machine read all the instructions for safe operation, as well as, the instructions governing the engine and other components of this machine.

TRAINING

- **Read the Owner's Manual carefully.** Be thoroughly familiar with the controls and the proper use of the equipment. Know how to stop the unit and disengage the controls quickly.
- Never allow children to operate the equipment. Never allow adults to operate the equipment without proper instruction.
- Operators should be mature enough to understand the dangers of the equipment.
- Never use your log splitter for any other purpose than splitting wood. Misuse can cause serious injury or death.

PREPARATION

- Always wear safety shoes. A dropped log can seriously injure your foot.
- Keep the area of operation clear of all persons, particularly small children and pets.
- Do not operate the equipment without wearing adequate outer garments.
- Loose clothing or jewelry may be caught by moving parts on the machine or by the surrounding environment and cause serious injury.
- Keep clothing away from all moving parts of your log splitter. Wear proper head gear to keep hair away from moving parts.
- Wear safety goggles to protect eyes from any debris or objects that may be thrown from the splitter.
- Always wear protective hearing devices as needed.
- If you wear gloves, be sure they are tight fitting without loose cuffs or draw strings.
- Handle fuel with care. It is highly flammable.
- Use only an approved fuel container.
- **Never add fuel to a running engine or a hot engine.**
- Fill fuel tank outdoors with extreme care. Never fill fuel tank indoors.
- Replace gasoline cap securely and clean up spilled fuel before starting.
- Never attempt to make any adjustments while the engine is running (except where specifically recommended by manufacturer).
- Do not operate splitter until you are familiar with all controls and safety symbols.
- Never operate your log splitter on slippery, wet, muddy, or icy surfaces. Safe footing is essential to safety.
- Operate your log splitter on level ground only. It could tip over. Rolling logs or poor footing could cause an accident.
- Always block wheels to prevent movement during operation.
- Never attempt to move the log splitter over hilly or uneven terrain without a tow vehicle or adequate help.

OPERATION

- Prepare logs properly. Both ends of each log should be cut as square as possible to help prevent the log from riding out of the splitter during operation.
- **Only operate the log splitter from the operator zone.**
- NEVER place hands or feet between log and splitting wedge or between log and ram during forward or reverse stroke. To do so may result in crushed or amputated fingers, toes, or worse. You could lose an arm or foot.
- Never straddle the log splitter when using it. A slip in any position could result in a serious injury.
- Never try to split two logs on top of each other. One may fly out and injure you.
- Never allow one person to operate the valve while another is positioning log, as serious injury could result from starting operation with the hands near the ram or wedge.
- Never operate the splitter indoors where exhaust from engine can collect. It contains carbon monoxide which is a tasteless, odorless, poisonous gas.
- Don't step over log splitter when the engine is running. Walk around.
- Take all possible precautions when leaving the machine unattended. Stop the engine.
- Never attempt to load your log splitter when the ram is in motion. You may get caught by the ram and be injured.
- If the splitter should start to vibrate abnormally, stop the engine and check immediately for the cause. Vibration is generally a warning of trouble.
- Only use your hand to operate the control lever. Never use your foot or a rope or any other extension device. This could result in your inability to stop your log splitter quickly and cause an injury.
- Do not put hands or feet near moving parts.
- Always keep fingers away from any cracks that open in the log during splitting operation. They can quickly close and pinch or amputate your fingers.
- Never move the log splitter while the engine is running.
- Operate equipment only in a well lit area. Do not use splitter after dark without artificial light.
- Never operate equipment when under the influence of drugs, alcohol, or prescription drugs which could cause drowsiness or poor judgement.
- Keep work area clean. Immediately remove split wood around your log splitter so that you do not stumble on it.
- Split wood with the grain. Do not attempt to split across the grain.

ASSUMPTION OF RISK: THE OWNER AND/OR OPERATOR OF THIS LOG SPLITTER ASSUMES ALL THE RISKS INCIDENT TO AND ARISING OUT OF THE OPERATION OF THIS MACHINE. BEFORE OPERATING THE LOG SPLITTER, READ ALL THE INSTRUCTIONS GOVERNING THE ENGINE AND THE SPLITTER.



Safety Information continued from page 2

MAINTENANCE

- Keep machine in good working condition.
- Do not alter your log splitter in any manner. Such alterations could cause your splitter to be unsafe.
- Before cleaning, repairing, or inspecting the machine, shut off the engine and make certain all moving parts have stopped. Disconnect spark plug.
- Follow the recommendations for maintenance described in this manual and the engine literature.
- Store gasoline only in an approved container.
- Never store machine with fuel in the fuel tank inside a building where open flame or spark are present. Allow engine to cool before storing in any enclosure.
- Frequently check all bolts and other connectors for proper tightness before operating the equipment.
- Replace safety decals as needed.

TOWING SAFETY

- Never tow your splitter at road speeds unless it is equipped with a suspension package.
- Obey all state and local regulations when towing on public roads and highways.
- Before towing, be certain that the splitter is correctly and securely attached to the vehicle. Attach the safety chain with slack for turning allowance.
- Don't allow anyone to sit or ride on your log splitter. They can easily fall off and be seriously injured.
- Before using your log splitter, disconnect it from the towing vehicle. A log can easily be pushed forward onto the vehicle.
- Never carry any cargo or wood on your log splitter. It may fall off and injure bystanders.

PREVENT FIRE

- NEVER operate your log splitter near a flame or spark. Hydraulic oil and gasoline are flammable and can explode.
- Don't fill the gas tank while the engine is hot or running.

Allow the engine to cool before refueling.

- Never smoke while operating or refueling your log splitter. Gas fumes can easily explode.
- If gasoline is spilled move machine away from the area of the spill and avoid creating any source of ignition until the spilled gas has evaporated.
- Take a class B fire extinguisher with you when operating your log splitter in dry areas as a precautionary measure.
- COMPLETELY drain the fuel tank prior to storage. This guards against accumulation of fuel fumes which could result in a fire hazard.

HYDRAULIC SAFETY

- The hydraulic system of your log splitter requires careful inspection along with the mechanical parts. Be sure to replace frayed, kinked, cracked or otherwise damaged hydraulic components.
- Fluid escaping from a very small hole can almost be invisible. Do not check for leaks with your hand. Escaping fluid under pressure can have sufficient force to penetrate skin, causing serious personal injury or even death. Leaks can be located by passing a piece of cardboard or wood over the suspected leak and look for discoloration.
- If injured by escaping fluid, see a doctor at once. Serious infection or reaction can develop if proper medical treatment is not administered immediately.
- Should it become necessary to loosen or remove any hydraulic fitting or line, be sure to relieve all pressure by shutting off the engine and moving the control handle back and forth several times.
- Don't remove the cap from the hydraulic tank or reservoir while your log splitter is running. Hot oil under pressure could result in serious injury.
- The pressure relief valve on your log splitter is preset at the factory. Do not adjust the valve. Only a qualified service technician should perform this adjustment.

5GG9A 6@M

1. You will need help lifting. Get help before you start.
2. Cut Bands and remove top part of crate.
3. With help lift the reservoir and engine assembly from crate and turn to rest it across the crate.
4. Install wheels. Apply a good grade of wheel bearing grease. Grease is available from any hardware store or auto parts store.
5. Install tongue using 1/2" x 4 1/2" capscrews (Ref. 52, Figure 2) and 1/2" (Ref. 13, Figure 2) nuts.
6. Lift assembly and put on level concrete or floor.
7. **Never attempt to lift Beam assembly unaided.** Stand I-Beam on end. Roll reservoir assembly to standing I-Beam. Attach I-Beam to reservoir assembly using 5/8" x 7 1/2" bolt (Ref. 17) and 5/8" Nylon Lock Nut (Ref. 15).
8. Lift beam into horizontal position and lock in place with lynch pin.
9. Connect hydraulic hoses. Remove 3/4" plug from reservoir. Screw in 3/4" return hose. This hose goes from the control valve to the reservoir.
10. Remove 1/2" plastic plug from pump. Attach high pressure hose going from control valve to pump.
11. Your log splitter is shipped with only enough fluid to prevent damage with accidental starting. There is not enough fluid to split wood. **Fill hydraulic reservoir 3/4 full.**
12. **Fill engine with oil according to engine manual.**

Operation

Before Starting Your Log Splitter . . .

1. **Check your Log Splitter.** Be sure all bolts are tight. After several hours of operating and at periodic maintenance intervals, check all fasteners and tighten securely as required.



WARNING : YOUR ENGINE IS SHIPPED WITHOUT OIL. YOU MUST FILL THE ENGINE WITH OIL BEFORE ATTEMPTING TO CRANK YOUR ENGINE.

2. **Check oil and fill according to the engine owner's manual.**

- Read Engine manual for full instructions and safety warnings.
- Place splitter on level ground.
- Clean around oil fill area.
- Remove dipstick. Wipe with clean cloth.
- Reinsert dipstick and tighten. Remove dipstick and check.
- Oil should be at FULL level.
- If oil is required, add slowly. Recheck level.
- Tighten dipstick and clean around oil fill area before starting.

3. **Fill engine with clean unleaded gasoline according to the engine owner's manual.**



WARNING: GASOLINE IS FLAMMABLE. USE CAUTION WHEN HANDLING OR STORING GASOLINE. NEVER FILL THE GAS TANK WHILE THE ENGINE IS RUNNING OR HOT. ALLOW THE ENGINE TO COOL BEFORE ADDING GAS. CLEAN ANY SPILLED GASOLINE.

4. **Check hydraulic fittings and tubing. Do not operate splitter with defective hydraulic assembly.**

5. **Check hydraulic fluid level. Do not operate splitter without hydraulic fluid.**

6. **Check the air cleaner element. Insure that the air filter is clean.**

7. **Familiarize yourself with all operating controls.**

Operating Controls

1. **Throttle --**

- To crank engine pull throttle all the way out to the choke position.
- To operate engine position the throttle to the 3/4 out position.
- To turn engine off push throttle all the way in.

2. **Operating Handle --**

- To split logs push handle forward towards the front of the splitter.
- To stop splitting action release handle.

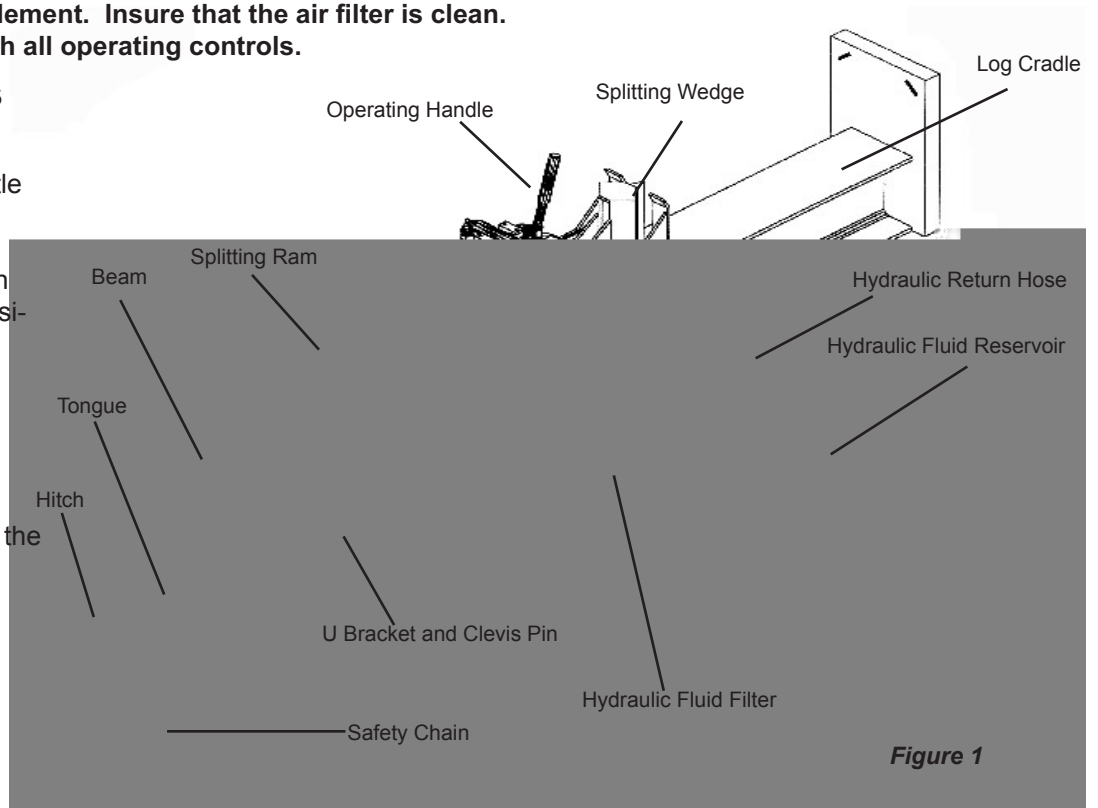

Figure 1



DO NOT ATTEMPT TO START OR OPERATE THIS SPLITTER UNTIL YOU ARE COMPLETELY FAMILIAR WITH LOCATION AND USE OF EACH CONTROL NECESSARY TO OPERATE THIS SPLITTER. YOU MUST KNOW HOW TO STOP THIS MACHINE BEFORE YOU START IT. EACH TIME PRIOR TO STARTING, CHECK THE THROTTLE ASSEMBLY TO INSURE IT IS WORKING PROPERLY.

Starting the engine

1. Read engine owner's manual for complete starting instruction. Do not operate this Splitter without reading the engine owner's manual.
2. Move the throttle control lever out to the START position.
3. Grasp rope handle and pull slowly until resistance is felt. Then pull cord rapidly to overcome compression, prevent kickback and start engine.
4. Operate engine in the 3/4 throttle position.

Splitting Wood

Logs may be split in either a vertical or horizontal position. To place splitter into the vertical position. Remove clevis pin from u-bracket on tongue (*see Figure 1*) and push beam into position. Reattach clevis pin.

1. Always keep hands and feet from the splitting area.
2. To prevent severe injury only one person should operate the log splitter. Any helpers or bystanders should remain at least 10 feet from the splitter.
3. Place log up to 26" long into log cradle.
4. Standing in the safe splitting zone, push long handle forward or down. When log is split release handle.
5. For best results and safety do not attempt to split across the grain of the wood.
6. Remove pieces and place a safe distance from the splitter.
7. Reload splitter.

Maintenance

There is very little maintenance with your Maxim Log Splitter.

Follow engine manual for taking care of your engine.

Before each use . . .

1. Check oil in engine.
2. Check hydraulic fluid.
3. Check to make sure all bolts holding the engine are tight.
4. Check to insure that all hydraulic fittings are tight.

After each use . . .

Clean dust and debris from engine.

After 25 splitting hours . . .

1. Check oil in engine.
2. Check hydraulic fluid.
3. Check and clean air filter.

After 100 splitting hours . . .

1. Change hydraulic fluid.

Hydraulic Fluid

1. To check fluid

- Place splitter on level ground.
- Remove fluid check plug (*See figure 1*).
- Insert clean dowel or other dip stick into hydraulic fluid tank. Level should be 1/2 to 3/4 full.
- Add fluid, if needed. Use any good universal tractor grade hydraulic fluid. You should be able to find the fluid at any Co-op, tractor supply, and many hardware stores. **Do not mix different types of fluid.**
- Recheck level.

2. To change fluid

- Unscrew hydraulic fluid filter (*See figure 1*)
- Drain old oil into an appropriate container. Dispose of properly.
- After the old hydraulic oil is drained, replace filter (Figure 4, #47a) and refill reservoir with any good quality universal tractor grade hydraulic fluid.

3. To remove air from the hydraulic line

- Lift rear wheels onto a raised surface.
- Block wheels.
- Start engine.
- Move operating handles forward and backward several times until the hydraulic ram moves smoothly.



Figure 2

Reference	Part #	Quantity	Description	Reference	Part#	Quantity	Description
1	358908	2	Lower Slide, Wedge	35	600208	1	Coupler Spider
2	358907	2	Spacer, Wedge	36	600203	1	3/4" ID Coupler
3	358906	1	Wedge Assembly		600209	1	1" ID Coupler (8hp)
5	400242	4	Capscrew, 1/2" x 2 1/2" NC5	37	455040	4	Flat Washer 1/4"
7	600371	1	3/4" Street Ell	38	600223	1	2 Stage Pump
8	600220	1	Pressure Hose	39	600218	1	Elbow Adapter, 45 degree
9	600212	1	Cylinder w/ Control Valve	40	600372	1	3/4" x 2" Nipple
	600212-A		Cylinder Only	41	461486	1	Vent Plug
	600212-B		Control Valve Only	42	358901	1	Tank Assembly
	461471		Clevis Pin Only	43	359309	2	Axle Spacer
	461460		Clip Pin Only	44	600257	2	Hose Clamp
10	131107	2	Spacer (As Required)	45	600314	1	1" ID x 13" Suction Hose
11	400110	4	Capscrew 1/4" x 3/4" NC	46	600219	1	Fitting, 45 degree 1" x 3/4"
12	446145	4	Lockwasher, 1/2"	47	600222	1	Filter and Adapter Assembly
13	443116	8	Nut, 1/2" NC	47A	600222-A	1	Hydraulic Filter Only
14	600221	1	Return Hose	48	162050	2	Wheel Assembly with Bearing
15	443815	1	5/8" NF Nylon Lock Nut	49	140120	2	Seal
16	443101	4	Nut, 1/4" NC	50	140121	2	Dust Cap
17	162049	1	5/8" x 7 1/2" Bolt, NF	51	461488	1	Lynch Pin 1/4"
18	358902	1	Beam Assembly	52	400250	4	Capscrew, 1/2" x 4 1/2" NC5
19	400304	1	9/16" x 3" Bolt NC5	53	400283	2	Capscrew, 3/8" x 4 1/2" NC5
20	444728	1	Nut, 9/16" NC Center Lock	54	443110	2	3/8" NC Nut
21	140119	4	Race	55	358911	1	Latch Bracket
22	140118	4	Bearing	56	461487	1	Stub Pin
23	443125	2	1" Castle Nut	57	446143	1	Lockwasher 5/8"
24	461470	2	Cotter Pin	58	443814	1	Nut NF, 5/8"
25	446136	12	5/16" Lockwasher	59	461489	1	PTO Pin
26	400186	4	Capscrew, 5/16" x 1" NC	60	600259	1	Safety Chain
27	600204	2	Fender	61	358910	1	Jack Stand
28	400194	4	Capscrew, 5/16" x 1 1/2" NC	62	358909	1	Tongue
29		1	Engine	63	600205	1	Hitch Coupler
30	443106	8	Nut, 5/16" NC	64	455051	1	Flat Washer, 5/8"
31	400189	4	Capscrew, 5/16" x 1" NF				
32	446130	4	Lockwasher, 1/4"				
33	600210	1	Pump Mounting Bracket (5.5-7 hp)				
	600211	1	Pump Mounting Bracket (8hp)				
34	600206	1	1/2" ID Coupler				

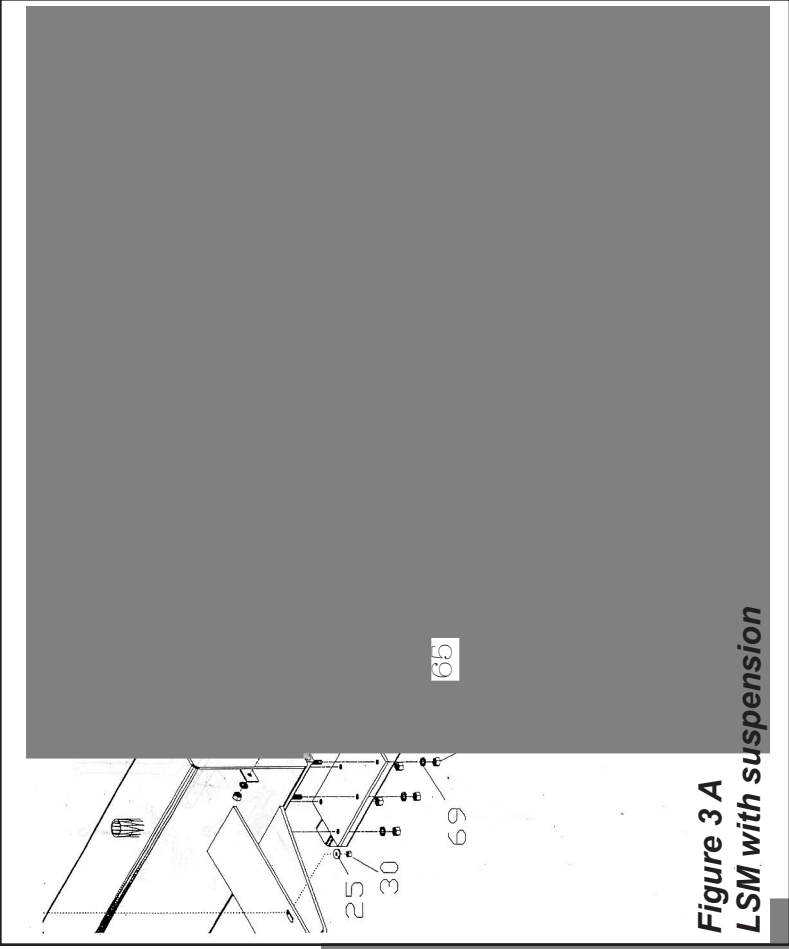

27

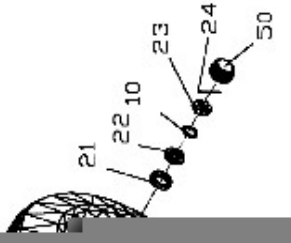
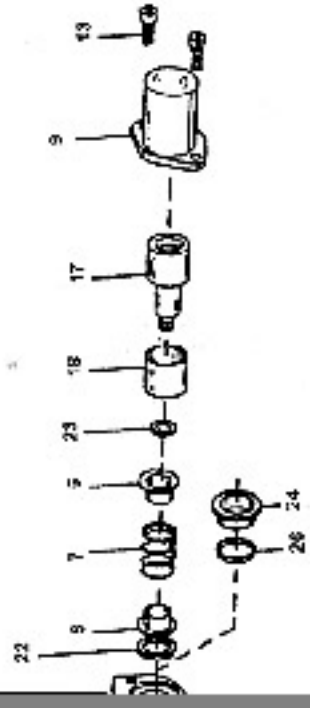

Figure 3

RTB



Part No.	Name	Qty.
80311	O-Ring, 7/8 x 1 1/16 OD	1
19282A	Steel Ball	1
82527	Plug, O-Ring, 1/2-20 UNF	1
A-2989	Detent Sub-Assy	1
A-2902	Spacer	1
80409	Clevis Pin, 1/4 x 1	1
80414	Cutter Pin, 3/32 x 1/2	1
81747	Washer, 5/8 x 1 DIA	1
81530	Lock Washer, 5/16	1
A-7093	Seal Retainer, 13/16 ID	1
19902A	Valve Seat	1
2755	O-ring, 13/16 ID x 1 1/16 OD	1
2832	Chain Link	1
-7514	Control Lever Bracket	1
-7238	Seal Kit contains all seals used in valve.	1

Energy Mfg. Co. Inc.
 24 Plastic Lane
 Pella, Iowa 52310-8472
 Phone: (319) 465-3537
 Fax: (319) 465-5279

The log splitter valve is a four-way control valve designed to operate a two-way hydraulic circuit from a single hydraulic source with an open center system.

Pull handle out to extend cylinder. Handle is spring loaded, will return to neutral when released. Push handle in to retract and the detent will hold the handle position. At the end of the stroke, the valve will sense pressure from the cylinder and the pressure will push the handle back to neutral position. This kick-out pressure varies from 750 to 1250 PSI during normal operating temperatures.

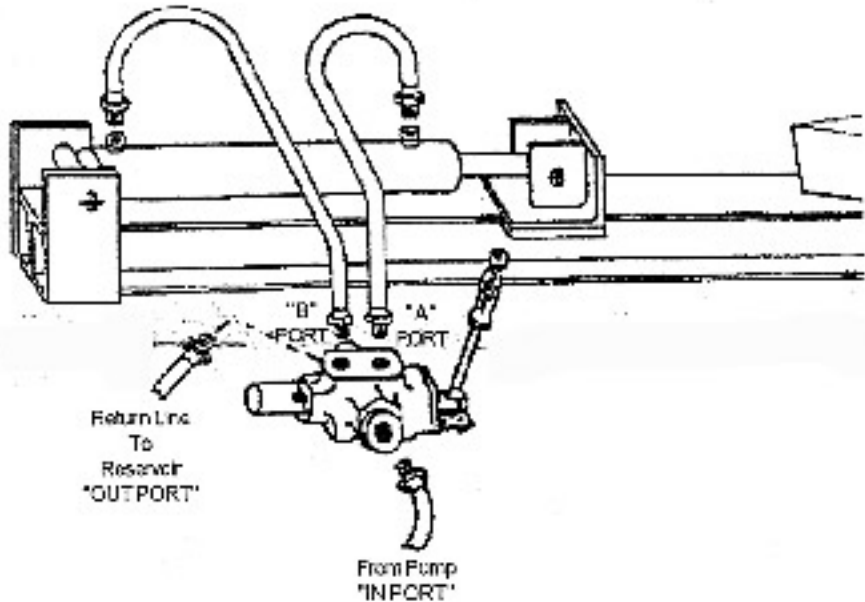

INSTALLATION

⚠ WARNING: Before installing product, read and understand all warnings, safety labels, and instructions. Failure to do so could result in Death or Serious Injury!

1. Install lever as shown in drawing.
2. Mount valve using 3/8"-16 NC tapped holes in the base of valve. **CAUTION:** Mounting valve to uneven mounting plate may cause the valve body to distort and the valve spool to bind. Move the control lever during the tightening procedure to assure that the valve spool does not lock or bind as a result of the tightening. Exerting heavy pressure on the control lever should be avoided as it may cause valve damage. If the valve spool binds anyway or refuses to return to neutral with the spring where the lever is released, discontinue use and call factory.
3. Make connections as shown in drawing. (NOTE: We do not recommend the use of teflon tape.)
4. Since the kick-out operates from hydraulic pressure (approx. 750-1250 PSI), the valve may not kick-

**OPERATING INSTRUCTIONS
LOGSPLITTER VALVES WITH HYDRAULIC KICK-OUT**



⚠ WARNING

DONOT GO NEAR LEAKS



⚠ WARNING

The logsplitter valve must never

Limited Warranty

Maxim Manufacturing Corporation, through its dealers will repair or replace any part, or parts of the LSM75BVG, LSM55H, or LSM80H frame that is defective in material or workmanship or both. **Transportation charges on parts submitted for repair or replacement under this Warranty must be borne by purchaser.** The original sales receipt must be submitted as proof of purchase date. The sales receipt will be returned. Maxim Manufacturing Corporation assumes no liability for labor charges made in performance of this warranty.

The Warranty period is one (1) year.

The Tires and Hydraulic Tubing are not warranted because during normal service they are subject to normal wear.

The Warranty on the Log Splitter is Void if:

- A. Frame is broken or bent due to abuse.
- B. Wheels are bent or broken due to impact.
- C. Altering of engine or its components has occurred.

All warranties are voided if the Splitter has been altered , rented, used under abnormal conditions, or subject to abuse, misuse, neglect, or improper maintenance.

The Engine is warranted by the engine manufacturer, not by Maxim Manufacturing Corporation. See Engine Owner's Manual for information regarding engine warranty.

Should you experience problems with your Log Splitter take it back to your authorized Maxim dealer or distributor to make warranty claims.

Maxim Manufacturing is not liable for any damage claim or liability claim, personal or otherwise, resulting from the operation of this splitter in any way.